

Resistance Gene Analogs (RGA) as a tool in fruit tree's breeding

Gutermuth, A. & Pedryc, A.

Corvinus University of Budapest, Faculty of Horticultural Science, Department of Genetics and Plant Breeding,
1118 Budapest, Villányi út 29., Hungary

Summary: Breeding for pest and disease resistance comes as a major objective behind the fruit traits. To increase the effectiveness of fruit resistance breeding application of the Marker Assisted Selection (MAS) is advantageous. For generating molecular markers which enable the following of interesting traits basically two methods are available: targeted marker design based on conservative region of already known Resistance (R) gene sequences or randomly generated markers. The creation and the application of these homology based markers are the object of this review in the main temperate zone fruit species.

Key words: Resistance Gene Analogue (RGA), Marker Assisted Selection (MAS), fruit breeding, functional marker

Introduction

Breeding for pest and disease resistance comes as a major objective behind the fruit traits. Fruit species are hosts to a wide range of pests and diseases, many of which need to be controlled in order for commercial production to be profitable (Gardiner et al., 2007). The use of plant resistance is widely regarded as the preferred means of controlling pest and diseases. There are socio-economic advantages in using resistant cultivars, because they help reduce environmental pollution from pesticide and production cost (Way et al., 1989).

Breeding of fruits differs fundamentally from annual vegetables because of the long juvenile stage, the obligatory dormancy, large tree size, self-incompatibility, high heterozygosity avoiding inbred degradation. The artificial infection methods applied during fruit resistance breeding are laborious and doubtful because the environmental conditions of the orchards can not be controlled.

To increase the effectiveness of fruit resistance breeding application of the Marker Assisted Selection (MAS) is advantageous. Major goal of the use of markers is increasing the breeding efficiency by enabling early selection for adult traits, simultaneous selection for multiple traits, including resistance pyramids, and selection for traits that are expensive and harmful to phenotyping.

For generating molecular markers which enable the following of interesting traits basically two methods are available: targeted marker design based on conservative region of already known Resistance (R) gene sequences or randomly generated markers. Sansavini and Tartarini (2003) called functional marker, which are based on the sequences similarity of genes with common resistance function. The creation and the application of these homology based markers are the object of this review in the main temperate zone fruit species.

Diversity and conservation of plant R-genes

Plant R proteins are part of a protein complex that functions in the plant surveillance system to detect the activities of pathogen effectors inside the host cell, rather than receptors for the pathogen-derived ligands. Many components of the complex defence signalling pathways have been identified and characterized. Moreover, biochemical cascades involved in some of the genetically defined signalling steps are being revealed (Xiao, 2006). In the past 15 years, over 60 plant R genes participating in activation of disease resistance to various pathogens ranging from nematodes, fungi, bacteria to viruses have been cloned (McHale, 2006). Isolation and characterization of this monogenic dominant plant disease resistance genes called R-genes have greatly advanced to understand of plant disease resistance primarily through some cognate pathogen avirulence factors that are recognized by the R genes, and many crucial signalling components in the conserved and complex R-gene pathways. This wide range of pathogen taxa and their presumed pathogenicity effector molecules, R genes encode only six classes of proteins, five of them take part a common signal transduction pathway (Dangl & Jones, 2001) (Figure 1).

The first group of R genes encodes receptor-like proteins (RLPs) that contain an extracellular LRR domain and a C-terminal membrane. This group of R genes are represented by tomato Cf2/4/5/9 conferring resistance to the fungal pathogen *Cladosporium fulvum* (Hammond-Kosack & Jones, 1997) and Arabidopsis RPP27 conferring resistance to *Peronospora parasitica* (Tor et al., 2004).

The second group of R proteins is comprised of members of a large family of receptor-like kinases (RLKs) that contain a cytoplasmic kinase domain in addition to the RLP structure. These R genes include rice Xa21 and Xa26, both of

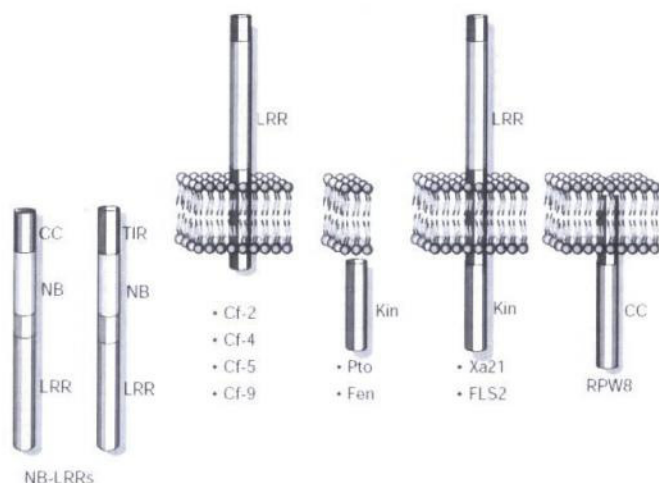

Figure 1: Representation of the location and structure of the five main classes of plant disease resistance proteins. Xa21 and Cf-X proteins carry transmembrane domains and extracellular LRRs. The recently cloned RPW8 gene product carries a putative signal anchor at the N terminus. The Pto gene encodes a cytoplasmic Ser/Thr kinase, but may be membrane associated through its N-terminal myristoylation site. The largest class of R proteins, the NB-LRR class, are presumably cytoplasmic (although they could be membrane associated) and carry distinct N-terminal domains (Dangl & Jones, 2001)

which confer resistance to multiple strains of *Xanthomonas oryzae* pv. *oryzae* (Sun et al., 2004), and FLS2 from *Arabidopsis* (Gomez & Boller, 2000), which encodes for the receptor of flg22, a bacterial elicitor that induces basal resistance.

The third group of R proteins is comprised of protein kinases. Pto from tomato confers resistance to *P. syringae* pv. tomato and is a member of a conserved protein kinase family (Martin et al., 1993).

The fourth group consists of atypical R proteins, each of which has a novel overall structure but possesses protein domains or motifs more or less similar to those in the R proteins mentioned above. The first cloned was the broad-spectrum powdery mildew R gene RPW8 from *Arabidopsis*, which encodes a small protein containing an N-terminal transmembrane (TM) and a CC domain (Xiao et al., 2001).

The fifth group comprises R genes that confer resistance with an entirely different mechanism. Instead of activating a signalling pathway leading to resistance, these enzymatic resistance (eR) genes produce enzymes to directly detoxify the pathogen-derived toxins (Johal & Briggs, 1992).

The sixth group – majority of the sequenced R genes (40) – encodes proteins containing a nucleotide-binding site and leucine-rich repeat motifs (NBS-LRR). Pathogen effectors from diverse kingdoms are recognized by NBS-LRR proteins, and activate similar defence responses. NBS-LRR-mediated disease resistance is effective against pathogens that can grow only on living host tissue (obligate biotrophs), or hemibiotrophic pathogens, but not against pathogens that kill host tissue during colonization (necrotrophs) (Glazebrook, 2005). These R proteins can be further subdivided into two major subclasses: those containing an N-terminal domain resembling the cytoplasmic signaling

domain of the *Drosophila* Toll and human Interleukin-1 (TIR) transmembrane receptors and those having a coiled-coil (CC) N-terminal domain (in most cases). TIR domain-containing animal proteins such as Toll and Toll-like receptors (such as TLR2, 4, 5, 9) are involved in innate immunity in animal system (Takeda & Akira, 2004). A homologous NBS domain is found in animal proteins Apaf1 and CED4 (Ceconi et al., 1998), which regulate apoptotic cell death, and both NBS and LRR domains are found in mammalian proteins NOD1 and NOD2, which function as intracellular receptors for bacterial LPS and play a key role in innate immunity (Inohara & Nunez, 2003). These findings collectively suggest an ancient origin for the function of NBS-LRR genes in activation of apoptosis-like hypersensitive cell death and innate immunity in plants (Dangl & Jones, 2001, Nurnberger et al., 2004). Consistent with this speculation, phylogenetic analysis indicated that a small number of NBS-LRR sequences exist among ancient angiosperms and that these ancestral sequences have diversified after the separation into distinct taxonomic families (Young, 2000).

The highly conserved NBS domain in the R proteins has been demonstrated to be able to bind and hydrolyse ATP and GTP and this domain is also found in other prokaryotic and eukaryotic proteins. Different from NBS domain, the LRR motif is typically involved in protein-protein interactions and responsible for recognition specificity (Dangl & Jones, 2001).

The consistent identification of this class of proteins across diverse plant species demonstrates that the NBS-LRR genes are a pillar of plant defences (Takken et al., 2006).

The NBS genes are abundant in plant genomes

Genes encoding NBS-LRR proteins comprise one of the largest gene families in plant genomes, with a total of 149 and 480 members identified in *Arabidopsis thaliana* and *Oryza sativa*, respectively (Meyers et al., 2003; Yang et al., 2006). Five hundred thirty-five and 416 NBS-encoding genes, including 459 and 330 NBS-LRR-encoding genes, were identified in grapevine and poplar, respectively (Yang, 2008). In grapevine 76 NBS type genes, which lacked LRR domains, were detected whereas in the poplar genome 86 genes were found without the LRR domain. More recently, approximately 330 NBS-encoding genes were detected in incomplete genome sequences (58% of the whole genome) of *Medicago truncatula* (Ameline-Torregrosa et al., 2008). Approximately 30,434, 45,555, 27,000 and 37,544 protein-coding genes were estimated in the full sequenced grapevine, poplar, *Arabidopsis* and rice genomes, respectively (Jaillon et al., 2007; Tuskan et al., 2006; *Arabidopsis* Genome Initiative 2000; International Rice Genome Sequencing Project 2005). The NBS-LRR genes accounted for approximately 1.51, 0.72, 0.53 and 1.23% of all predicted ORFs in these four species, respectively (Yang et al., 2008).

The NBS genes are clustered in plant genomes

Next to the abundance (high frequency), it is another important property that most NBS-LRR genes are unevenly distributed in plant genomes and existing mainly as multi-gene clusters. Studies in *Arabidopsis* and rice report an uneven distribution of NBS-encoding genes on chromosomes (Meyers et al., 2003; Zhou et al., 2004). The majority of NBS-containing genes in the grapevine (83.2%) and the poplar (67.5%) genomes were found in clusters. In two woody species, grapevine and poplar higher percentage of NBS-encoding genes positioned in numerous clusters, by this result Yang (2008) suggested recent tandem duplication played a major role in NBS-encoding gene expansion in perennial species.

The clustered distribution of R-genes provides a reservoir of genetic variation from which new specificities to pathogens can evolve via gene duplication, unequal crossing-over, ectopic recombination or diversifying selection (Michelmore & Meyers, 1998).

Conservation of the R genes gives possibility to simply isolation of similar sequences: the RGA's

NBS and the Serine/Threonine kinase domain from the receptor kinase (RLK) group display the highest level of cross-species homology in terms of amino acid sequence conservation (Figure 2). Taking advantage of this fact, degenerate PCR primers have been proposed that should permit the isolation of homologous sequences, from any plant species by heterologous amplification (Kanazin et al., 1996).

This approach has provided a powerful tool to isolate NBS or RLK part of R-like genes from any plant genome without prior genomic information. Principally these sequences which show high similarity annotated plant resistance genes could be known as Resistance Gene Analog (RGA) (Kanazin et al. 1996) or Resistance Gene Homolog (RGH) (Leister et al., 1996) when the common origin accepted. This method so popular among the researcher that

over 1,600 NBS sequences have been amplified from a diverse array of plant species using degenerate PCR primers (McHale et al., 2006).

Three main temperate zone fruit species may be a success illustrative

Every new strategy are applied firstly on the model species as *Arabidopsis* and then followed economically important annual crop species as soya bean, maize, potato. After that turn the perennial species as grape, apple and peach. In these part we present the main results of creation and application these RGA approach for resistance trait.

The *Vitis vinifera* L. grape is one of the oldest cultivated plants. The most common fungal disease in the world's grape growing region is powdery mildew, caused *Uncinula necator*.

This fungus was unintentionally introduce to Europe from North America before the 1850s (Reisch & Pratt, 1996). About 20 years later downy mildew caused another fungus, *Plasmopara viticola*, become a serious problem. For this marker ensuing the resistance trait against these biotrophs was sought out in the followings.

Di Gaspero and Cipriani (2002) developed first candidate markers for disease-resistance genes in grape which based RGA sequences. Bulked segregant analysis strategy was applied to screen for restriction fragment length polymorphisms linked to downy mildew resistance locus. Three resistance *Vitis* species *V. amurensis*, *V. riparia*, *V. cinerea*, three susceptible *V. vinifera* cultivars: 'Cabernet Sauvignon', 'Chardonnay', 'Merlot' and three interspecific hibryds 'Seyval', 'Regent', 'Bianca' were analysed. Lack of the segregating population they didn't have any evidence from genetic mapping that these sequences are linked to disease resistance genes, it was shown that probes obtained from grape NBS-sequences, when blotted to genomic DNA of different species and genotypes, gave a hybridisation signal only in disease resistant species and tolerant/resistant hybrids. The signal was lacking in susceptible varieties of the cultivated European grapevine.

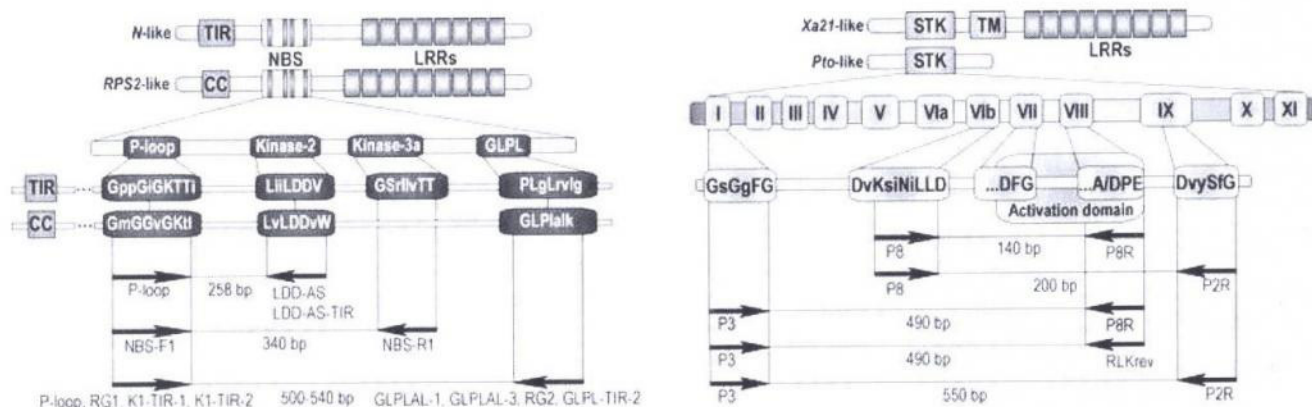

Figure 2: Model of NBS-LRR (left) and receptor-like kinase (right) classes of R-gene products, showing the most highly conserved segments within the nucleotide binding site and serine/threonine kinase domains, and their consensus sequences. The arrows indicate the annealing sites and the 5'3' orientation of the degenerate primers used Di Gaspero & Cipriani (2003) and the predicted lengths of the amplified fragments are also given

Donald et al. (2002) examined the well characterised powdery mildew resistance (*Run1*) introgressed into *Vitis vinifera* L. from the wild grape species *Muscadinia rotundifolia*. The main difference in the method was that they applied a segregation population next to the BSA. Three RGA markers were found to be tightly linked to the *Run1* locus. Of these markers, two (GLP1-12 and MHD145) co-segregated with the resistance phenotype in 167 progeny tested, whereas the third marker (MHD98) was mapped to a position 2.4 cM from the *Run1* locus. The results demonstrated firstly the usefulness of RGA sequences, when used in combination with bulked segregant analysis, to rapidly generate markers tightly linked to resistance loci. The high number of RFLP patterns identified in the restriction experiment suggests a very high polymorphism for these fragments at the nucleotide sequence level, because this method screens the polymorphism inside the NBS domain and also screen the flanking region.

Next to the NBS class of RGA's Di Gasparo et al. (2003) investigated Serine/Threonine Kinase (STK) gene analogs in grape with the aim of developing a set of resistance-related sequence-tagged-site (STS) markers. Twelve degenerate primers designed to anneal to the sequences encoding the four most conserved segments of the NBS domains were used, 487 plasmid clones were fingerprinted by means of SSCP analysis of the inserts, total of 132 clones were sequenced. 103 unique sequences showed significant similarity to known *R*-genes. They identified 29 well supported groups of grape NBS-LRRs useful for specific primer design. NBS-LRR sequences obtained with a given combination of degenerate primers showed a tendency to cluster closely together on dendrograms.

Five degenerate primers were newly designed to anneal to sequences coding for the most conserved stretches within the Serine/Threonine Kinase domains specified by some receptor-like *R*-genes. All combinations of degenerate primers were found to amplify the expected bands from genomic DNAs of *V. amurensis* and *V. riparia*. After cloning, a total of 177 inserts were fingerprinted by SSCP analysis. Seventy-three of those having the most distinct SSCP banding patterns were sequenced.

Finally, 45 universal primers for grape RGAs are proposed that should permit tagging of *R*-related regions in any grape genome, but they didn't confirm the co-segregation with any resistance trait in mapping population. The main message of this work that the more primer combination to apply the more wide distributed sequences resulted.

Di Gasparo (2007) grapevine integrated genetic map, where 82 functional markers derived from analogs of resistance genes were placed together with 420 SSR markers recovered from the literature and the NCBI database. They offer such a map as a valuable tool for geneticists and breeders working in pest and disease resistance in grape, who can find, a set of markers that identify a significant number of RGA clusters co-localisation of RGA markers and known phenotypic loci of disease resistance. A major QTL for

downy mildew resistance inherited from *Vitis* hybrid 'Regent' has been identified in the region close to SSR marker VMC6f11 (Fischer et al., 2004), RGA marker rgVrip064 found to be associated with downy mildew resistance in some resistant genotypes (Di Gasparo & Cipriani, 2002) is also located in the same region. The cluster of NBS-LRRs identified by markers GLP1-12, MHD98, MHD145 in the surroundings of *Run1* (Donald et al., 2002; Barker et al., 2005) and originating from *M. rotundifolia*, had a counterpart in the *Vitis* genome, which spanned the middle to one end of LG 12.

After the grape's whole genome sequences Yang et al. (2008) assessed that the majority of NBS-containing genes in the grapevine (83.2%) genome were found in clusters. In grapevine, 77 clusters, including 445 NBS genes, were identified. On an average, 5.78 NBS members were detected in a cluster, which could be slightly underestimated due to unanchored scaffold sequences. The largest cluster, comprised of 26 NBS members.

After the principal apple breeding objective – the marketability of the fruit – the fungal and bacterial disease resistances are the most important point of view. Consumer objection to the use of pesticide was a significant driver for apple breeders to include resistance breeding as a major topic in the development of new cultivars (Laurens, 1999). Apple has proved to be a rich source of simply inherited resistance genes with major effects against apple scab caused by *Venturia inaequalis*, powdery mildew caused by *Podosphaera leucotricha* and aphids as *Eriosoma lanigerum*, *Dysaphis devectora*. Therefore it was promising to develop and map NBS derived RGA markers.

Baldi et al. (2004) gave the first report from the cloning and characterization of 30 apple resistance genes homologues (ARGHs) using degenerate primers designed to bind the P-loop, kinase-2, and GLPL elements of the NBS region. They show that multiple and diverse ARGHs exist in the apple genome. Eighteen of these were mapped using a linkage map of the apple cultivars 'Fiesta' and 'Discovery'. For the genetic mapping of the cloned ARGH sequences 27 primer pairs were designed on the divergent DNA sequence regions. When genomic DNA of the two cultivars was amplified with all 27 primer pairs, only a primer pair showed a presence/absence polymorphism on agarose gel. A single band of the same, expected size was observed for all the other ARGHs. Even after digestion with a panel of four-cutter restriction enzymes, only 3 out of 26 ARGHs showed polymorphisms on agarose gel, indicating that very few differences were present at the 'Fiesta' and 'Discovery' amplified alleles. Using the SSCP technique, a polymorphism between 'Fiesta' and 'Discovery' could be identified in 14 additional sequences. They found several of the cloned RGAs appeared to map in clusters. An NBS-containing gene cluster could be represented by ARGH17 and ARGH37, which were placed in the same position on linkage group 2 and are very similar to each other. ARGH30 and ARGH02 cannot be considered members of a gene cluster due to their phylogenetic distance, in spite of the fact

that they are tightly linked on the map. Nevertheless the presence of members of two different ARGH families in the same position could indicate the presence of a "hot spot" on the apple genome containing multiple NBS-LRR sequences.

Calenge et al. (2005) applied modified method called nucleotide-binding site (NBS) profiling to identify and map resistance gene analogues (RGAs) in apple. This modified PCR method offer to use an adapter primer matching a restriction enzyme site and of a degenerate primer targeting the NBS-encoding region. One primer is therefore anchored in the NBS-encoding region and genetic variation is sampled in the gene region flanking the primer-binding site. NBS-profiling was shown to be highly effective in generating polymorphic markers with high sequence homology to RGAs in several species (Van der Linden et al., 2004). Fifty-two polymorphic markers were observed in the Discovery × TN10-8 progeny across the three enzyme/primer combinations tested, of which 43 could be mapped.

After the sequencing the polymorphic band only 23 sequences displayed homologies with R genes or RGAs but remarkable to know this sequences derived out of the NBS domain whereas the majority of the RGA sequences populating the sequence databases, including a number of apple RGAs (Lee et al., 2003), correspond to the NBS domain itself.

On LG 2, the major scab resistance gene *Vr2* co-segregated with several NBS marker in their progenies while three NBS markers were mapped close to the putative position of *Pl-w* the major powdery mildew resistance. Four NBS markers mapped close to the putative position of *Vd* in their progeny On LG 10. *Vd* is the major scab resistance gene, previously identified in the apple cultivar 'Durello di Forli'. For each of the three co-localizations mentioned, NBS markers could become useful makers for MAS or map-based cloning once converted to breeder-friendly markers and mapped in the appropriate progeny. The difficulty to use this marker for apple MAS that they didn't allocate the distance in cM and the few number of the progenies in the segregating population.

Within the *Prunus* genus interspecific hybrids are widespread exist, the transferable markers (RFLPs, SSRs and isozymes) between species well adoptable and comparative mapping shows that the order and distribution of the markers into the eight linkage groups was generally identical between species suggesting a high degree of synteny. Therefore *Prunus* species are discussed together often in genetic research (Abott, 2007).

Bliss et al. (2002) first isolated and mapped on an interspecific cross between almond and peach NBS RGA sequences. The NBS sequences amplified from 'Okinawa' peach which is resistant to root-knot nematodes (RKN) were probes used for the RFLP. Seven NBS RGA markers were mapped into linkage groups-1,-2 and-8. Lack of resistance phenotypes they couldn't recognize any co-segregation.

Plum pox potyvirus (PPV) infection causes the most devastating disease of *Prunus* that drastically reduces commercial mainly plum and apricot production. (Ravelonandro et al., 2000). Several genes are involved in

resistance to Plum pox potyvirus in peach and apricot (Vilanova et al., 2003). It might be one reason why apricot was chosen. Dondini et al. (2004) used NBS type RGA functional marker to develop primer pairs to be associated with Sharka resistance in apricot. They used BSA analysis from 17 apricot accessions and resistance derived from the North American variety 'Stark Early Orange'. Thirty of the sequenced clones showed a high degree of homology (over 60%) with known resistance genes which derived the usage of single but not degenerated primer pair. The forward primer was designed to correspond to the P-loop region of L6 gene while the reverse primer was made corresponding to the GLPL region of N gene. Eight RGA families were distinguished by sequence analysis. Primer pairs designed on hyper-variable regions identified by the eight RGA group. The best association between an RGA marker and Sharka resistance is shown by the primer pair SEOBT101 that amplify a band of about 300 bp that seems strictly associated with the expression of resistance: this band appears in all resistant genotypes and never in the susceptible cultivars. Unfortunately this marker linkage did not prove on a segregation population for this the distance could not determinate. A point of interest that this marker has never mentioned in any other publication although the topic of Sharka resistance in *Prunus* is very highlighted recently.

Soriano et al. (2005) also isolated and cloned from apricot RGA using a PCR approach with degenerate primers designed from conserved regions of the NBS domain. The degenerated primers used in this study were designed based on three genes: the non-TIR-NBS-LRR RPS2 gene from *Arabidopsis*, and two TIR NBS LRR genes. First was the L6 gene from flax and the other was the N gene from tobacco. In both studies all the isolated sequences were grouped to the TIR-NBS-LRR RGA class, lack of the CC-NBS-LRR RGA class offers a defect of the used primer pairs or PCR condition. Restriction digestion and sequence analyses of the amplified fragments led to the identification of 43 unique amino acid sequences grouped into six families of resistance gene analogs (RGAs). RGA-specific primers based on non-conserved regions of the NBS domain were developed from the consensus sequences of each RGA family. These primers were used to develop amplified fragment length polymorphism (AFLP)-RGA markers by means of an AFLP-modified procedure where one standard primer is substituted by an RGA-specific primer. This method equal which Calenge et al. (2005) applied and called nucleotide-binding site (NBS) profiling in apple. Using this method, 27 polymorphic markers, six of which shared homology with the TIR class of the NBS-LRR R-genes, were obtained from 17 different primer combinations. Of these 27 markers, 16 mapped in an apricot genetic map previously constructed from the self-pollination of the cultivar 'Lito', but they didn't realise any co-segregation with examined PPV resistance.

However there are dissimilar hypotheses about the number of genes controlling the PPV resistance trait. Martinez-Gomez and Dicenta (2000) suggested single gene, Moustafa et al. (2001) suggested two genes to control this

trait, while *Guillet-Bellanguer and Audergon* (2002) suggested three genes which control the trait. This inconsistency shows that producing a segregation population and reliable evaluation of the resistance trait is big challenge.

Candidate genes representing NBS-LRR, kinase, transmembrane domain classes, as well as, pathogen response (PR) proteins and resistance-associated transcription factors were hybridized to a peach BAC library and mapped by using the peach physical map database and the Genome Database for Rosaceae (GDR) without the use of segregating population (*Lali et al.*, 2005). A resistance map for *Prunus* was generated and currently contains 42 map locations for putative resistance regions distributed among 7 of the 8 linkage groups. More than a half part of the map location predict NBS type RGAs. Of the 30 probes which proved to be informative for mapping, only 17 returned BLAST results with sequence similarity to resistance genes of the NBS-LRR class. Sequence comparison revealed two distinct clusters of RGAs, with majority of the RGAs belonging to the TIR-NBS-LRR class. At this juncture, it is not possible to determine if this is due to a greater abundance of this class of RGA in the *Prunus* genome or a bias in the amplification of RGAs due to limitations of primer design. Mapping of RGAs indicated separate clustering of TIR and non-TIR NBS-LRRs in the *Prunus* genome. Although they didn't apply the segregation population several of these probes mapped to locations where QTLs for resistance mapped for traits such as powdery mildew (*Dirlwanger et al.*, 2004) and Sharka resistance (*Decroocq et al.*, 2005). Moreover, 3 amplified RGAs mapped to the region of G7 that is known to contain the *Ma* gene or on G2 close to the *RMai* gene, both of which control resistance to root-knot nematodes (*Dirlwanger et al.*, 2004). *Foulongne et al.* (2003) described the QTLs, with the strongest effect for powdery mildew caused by *Sphaerotheca pannosa*, as being located in G6 and G8 they mapped RGAs in the region of the QTL for powdery mildew in G6 but not in G8. On the other hand these promising result to date can't be applied in *Prunus* resistance breeding because the co-segregation of markers with any trait is not determined.

Functional markers derived From RGA's may accelerate fruit's resistance breeding

Most of the molecular researchers to date has focused on identifying genetic markers for pest and disease resistance genes. To date the primary use of genetic markers in resistance breeding has been in the application of marker-assisted selection (MAS) for pyramid resistance genes in seedling progenies, but they also are an important tool for germplasm screening for sources of resistance, in host-pathogen interaction research, and map based-cloning of resistance genes (*Gardiner et al.*, 2007), although *Deng and Gmitter* (2003) noticed that the long generation times, large tree sizes, or complex genetic behaviours, genetic mapping and map based cloning of disease resistance genes could not be readily performed in fruit tree species.

RFLP, RAPD, SSR and AFLP markers are only genetically linked to the trait of interest and no functional relationship can be inferred. Recently more attention has been focused on identifying differences in specific DNA sequences putatively involved in the expression of given traits. These difference that might be related to the gene function and to the phenotype have been called functional markers. The availability of many different sequences in DNA databases increased the possibility to produce functional markers in any species simply by a simple PCR approach. Three main examples have successfully been used in both apple and pear by using functional marker for PCR reaction. The *S-RNase* single locus, ACC-synthase and oxidase gene, and NBS type RGA sequences associated to resistance trait.

Isolation and mapping of such RGAs permit to target regions spanning major genes or QTLs for disease resistance in several crops. RGAs have frequently been found to localise to gene clusters or hot spots controlling resistance against more than one pathogen (*Di Gaspero*, 2003), hence it might be a powerful tool to accelerate fruit tree's breeding (*Tartarini & Sansavini*, 2003).

Whole genome sequences show important traits of the main R genes group the nucleotide-binding site (NBS) and leucine-rich repeats (LRRs). In perennial species (grape and poplar) higher percentage of this sequences were positioned in numerous clusters and higher nucleotide identity among paralogs were observed (*Yang et al.*, 2008). This observation increase the consequence of the usage this sequences for the base of linked marker generating to resistance. Targeted approach of these resistance gene clusters may be a successfully and fast method to receive co-segregating markers. Although the determination this markers substantive distance from the genetic determinant region must use mapping population, which also necessary for the Map Based Cloning (MBC) of this genes. According to *Jander et al.* (2002) it takes less than 1 person-year to isolate a gene in *Arabidopsis* with MBC, application of similar tools in cloning citrus gene would take a much longer time to reach the goal. For example Ctv, the only Citrus gene upon which extensive MBC effort have been made, has taken about ten years to reach the last step partly due to genetic restrains (*Fred et al.*, 2007). Similarly these result ten years have passed from the first report (*Manganaris et al.*, 1994) of a linked marker to Vf until the cloning and annotating (*Belfanti et al.*, 2004) the HcrVf2 apple resistance gene.

The first differences between generate a co-segregate marker on genetic model plant *Arabidopsis* and woody species -majority of fruit species- consumed time to build up a mapping population. The second is a reliable evaluate a resistance trait, the clear phenotype.

The lack of a segregating population may apply Bulk Segregant Analysis (BSA) method for rapidly identifying markers associated with the resistance trait where each bulk contains individuals that are identical for a particular trait or genomic region but arbitrary at all unlinked regions. The two bulks are therefore genetically dissimilar in the selected region but seemingly heterozygous at all other regions

(Michelemore et al., 1991). Although this prime method establish the two bulks from a segregation population individuals, some other case this bulks often made for resistance and susceptible varieties or species, where the resistance origin was common (Di Gasparo & Cipriani 2002, Dondini et al., 2004).

Molecular marker derived from RGA sequences may be a helpful opportunity for fruit resistance breeding but able to exchange the classical evaluation methods of plant resistance only the case could happen if these markers detect the real genetic determinant sequences.

Conclusion

Fruit breeding is a vary difficult task mainly of the long juvenile phase and the very high level of heterozygosity most of the fruit species. All of the development of new techniques for the early and reliable selection of seedling carrying valuable traits has become a priority in fruit breeding. The development of molecular markers linked to important resistance trait has already made it possible to improve and to accelerate some selection procedures.

According to Sansavini (2003) significant result from the use of MAS could exist mostly monogenic trait. The identification of QTL's in fruit trees is rather difficult as the two parents are highly heterozygous and the segregation analysis of each quantitative trait requires large progenies to increase its reliability.

RGA functional markers derived from NBS sequences mapped often such regions where previously RAPD, AFLP and SSR linked to resistance trait. One of the most important step the generation of the RGA based molecular markers is the primer design mostly the degeneracy level and the number of the primer combination. The confirmation of these conclusion are two things NBS-LRR sequences obtained with a given combination of degenerate primers showed a tendency to cluster closely together on dendrograms and the second is the unequal ratio the TIR- and CC-NBS-LRR type sequences in the examined *Prunus* genotypes. The reliable reason of these unequal ratio according the dicots species whole genome sequences is the bias of the applied primer set and PCR strategy. These sequences were amplified with a limited number of NBS domain-based degenerate primers, and as a group they may not actually represent the breadth of plant R-gene repertoires in *Prunus*.

In grape some RGA marker as a functional marker show closer co-segregation with resistance as the earlier mapped redundant resistance markers. Two (GLP1-12 and MHD145) co-segregated with the resistance phenotype in 167 progeny tested which are a demonstrative precedent for the availability of this method. On the other hand in apple Baldi et al. (2004) mapped some marker linked with resistance against apple scab, but genetic mapping was performed with only 44 individuals from the Fiesta × Discovery cross, hence this marker already insecure tools for apple MAS.

For MAS the markers can be applied which are not only BSA analysis linked but mapped on a segregation population contains competent number of progenies.

Important to observe from the six well characterized R-gene group the highlighted NBS-LRR group is only one of them, that means the other five group are excluded from the potential responsibility. Unfortunately they receive reliable linked markers if the resistance is coded NBS-LRR type gene. Some RLK type marker were mapped on peach and grape genomes, but the sequenced analysis show no similarity with known RLK type resistance genes.

A part of these results demonstrate the usefulness of RGA sequences to rapidly generate markers tightly linked to resistance loci in fruit species, and care to upper estimated the opportunity these approach to develop molecular markers linked resistance trait.

References

- Abbott, A.G., Arús, P. & Scorza, R. (2007): Peach. (In: Kole C., eds. *Genome Mapping and Molecular Breeding in Plants, Volume 4 Fruits and Nut.*) Springer-Verlag Berlin Heidelberg. 137–156.
- Ameline-Torregrosa, C., Wang, B.B., O'Bleness, M.S., Deshpande, S., Zhu, H., Roe, B., Young, N.D. & Cannon, S.B. (2008): Identification and characterization of NBS-LRR genes in the model plant *Medicago truncatula*. *Plant Physiol.* 146: 5–21.
- Arabidopsis Genome Initiative (2000): Analysis of the genome sequence of the flowering plant *Arabidopsis thaliana*. *Nature.* 408: 796–815.
- Baldi, P., Patocchi, A., Zini, E., Toller, C., Velasco, R. & Komjanc, M. (2004): Cloning and linkage mapping of resistance gene homologues in apple. *Theor Appl Genet.* 109: 231–239.
- Barker, C.L., Donald, T., Pauquet, J., Ratnaparkhe, M.B., Bouquet, A., Adam-Blondon, A.F., Thomas, M.R. & Dry, I. (2005): Genetic and physical mapping of the grapevine powdery mildew resistance gene, *Rm1*, using a bacterial artificial chromosome library. *Theor Appl Genet.* 11: 370–377.
- Belfanti, E., Silfverberg-Dilworth, E., Tartarini, S., Patocchi, A., Barbieri, M., Zhu, J., Vinatzer, B.A., Gianfranceschi, L., Gessler, C. & Sansavini, S. (2004): The *HcrVf2* gene from a wild apple confers scab resistance to a transgenic cultivated variety. *Proc Natl Acad Sci USA* 101: 886–890.
- Bliss, F.A., Arulsekar, S., Foolad, M.R., Becerra, V., Gillen, A.M., Warburton, M.L., Dandekar, A.M., Kocsisne, G.M. & Mydin, K.K. (2002): An expanded genetic linkage map of *Prunus* based on an interspecific cross between almond and peach. *Genome.* 45: 520–529.
- Cecconi, F., Alvarez-Bolado, G., Meyer, B.I., Roth, K.A. & Gruss, P. (1998): Apaf1 (CED-4 homolog) regulates programmed cell death in mammalian development. *Cell.* 94: 727–737.
- Dangl, J.L. & Jones, J.D.G. (2001): Plant pathogens and integrated defence responses to infection. *Nature* 411: 826–832.
- Dicroocq, V., Foulongne, M., Lambert, P., Le Gall, O., Mantin, C., Pascal, T., Schurdi-Levraud, V. & Kervella, J. (2005): Analogues of virus resistance genes map to QTLs for resistance to sharka disease in *Prunus davidiana*. *Mol. Genet. Genom.* 272: 680–689.

- Di Gaspero, G. & Cipriani, G. (2002):** Resistance gene analogs are candidate markers for disease-resistance genes in grape (*Vitis* spp.). *Theor Appl. Genet.* 106: 163–172.
- Di Gaspero, G. & Cipriani, G. (2003):** Nucleotide binding site/leucine-rich repeats, Pto-like and receptor-like kinases related to disease resistance in grapevine. *Mol. Genet. Genomics.* 269: 612–623.
- Dirlewanger, E., Cosson, P., Howad, W., Capdeville, G., Bosselut, N., Claverie, M., Voisin, R., Poizat, C., Lafargue, B., Baron, O., Laigret, F., Kleinhentz, M., Arus, P. & Esmenjaud, D. (2004):** Microsatellite genetic linkage maps of myrobalan plum and an almond-peach hybrid—location of root-knot nematode resistance genes. *Theor Appl. Genet.* 109: 827–838.
- Donald, T.M., Pellerone, F., Adam-Blondon, A.F., Bouquet, A., Thomas, M.R. & Dry, I.B. (2002):** Identification of resistance gene analogs linked to a powdery mildew resistance locus in grapevine. *Theor Appl. Genet.* 104: 610–618.
- Dondini, L., Costa, F., Tataranni, G., Tartarini, S. & Sansavini, S. (2004):** Cloning of apricot RGAs (Resistance Gene Analogs) and development of molecular markers associated with Sharka (PPV) resistance. *Journal of Horticultural Science & Biotechnology* 79: 729–734.
- Fischer, B.M., Salakhutdinov, I., Akkurt, M., Eibach, R., Edwards, K.J., Töpfer, R. & Zyprian, E.M. (2004):** Quantitative trait locus analysis of fungal disease resistance factors on a molecular map of grapevine. *Theor Appl. Genet.* 108: 501–515.
- Fred, F.G., Chen, C., Rao, M.N. & Soneji, J.R. (2007):** Citrus fruits (In: Kole C, eds. *Genome Mapping and Molecular Breeding in Plants, Volume 4 Fruits and Nut.*) Springer-Verlag Berlin Heidelberg. 265–275.
- Gardiner, S.E., Bus, V.G.N., Rusholme, R.L., Chagné, D. & Rikkerink, E.H.A. (2007):** AppleIn: Kole C, eds. *Genome Mapping and Molecular Breeding in Plants, Volume 4 Fruits and Nut.* Springer-Verlag Berlin Heidelberg. 1–53.
- Glazebrook, J. (2005):** Contrasting mechanisms of defense against biotrophic and necrotrophic pathogens. *Annu. Rev. Phytopathol.* 43: 205–227.
- Gomez-Gomez, L. & Boller, T. (2000):** FLS2: an LRR receptor-like kinase involved in the perception of the bacterial elicitor flagellin in Arabidopsis. *Molecular Cell* 5: 1003–1011.
- Hammond-Kosack, K.E. & Jones, J.D. (1997):** Plant Disease Resistance Genes. *Annual Review Plant Physiology and Plant Molecular Biology.* 48: 575–607.
- Inohara, N. & Nunez, G. (2003):** NODs: intracellular proteins involved in inflammation and apoptosis. *Nature Reviews Immunology* 3: 371–382.
- International Rice Genome Sequencing Project (2005):** The map-based sequence of the rice genome. *Nature.* 436: 793–800.
- Jaillon, O., Aury, J.M., Noel, B., Policriti, A., Clepet, C. et al (2007):** The grapevine genome sequence suggests ancestral hexaploidization in major angiosperm phyla. *Nature.* 449: 463–467.
- Jander, G., Norris, S.R., Rounsley, S.D., Bush, D.F., Levin, I.M. & Last, R.L. (2002):** Arabidopsis map-based cloning in the post-genome era. *Plant Physiol.* 129: 440–450.
- Johal, G.S. & Briggs, S.P. (1992):** Reductase activity encoded by the HM1 disease resistance gene in maize. *Science.* 258: 985–987.
- Kanazin, V., Marek, L.F. & Shoemaker, R.C. (1996):** Resistance-gene analogs are conserved and clustered in soybean. *Proc. Natl. Acad. Sci. USA.* 93: 11746–11750.
- Laurens, F. (1999):** Review of the currant apple breeding programmes in the world: objectives of scion cultivar improvement. *Acta Hort.* 484: 163–170.
- Lalli, D.A., Decroocq, V., Blenda, A.V., Schurdi-Levraud, V., Garay, L., Le Gall, O., Damsteegt, V., Reighard, G.L. & Abbott, A.G. (2005):** Identification and mapping of resistance gene analogs (RGAs) in Prunus: a resistance map for Prunus. *Theor Appl. Genet.* 111: 1504–1513.
- Lee, S.Y., Seo, J.S., Rodriguez-Lanetty, M. & Lee, D.H. (2003):** Comparative analysis of superfamilies of NBS-encoding disease resistance gene analogs in cultivated and wild apple species. *Mol. Genet. Genomics.* 269: 101–108.
- Leister, D., Ballvora, A., Salamini, F. & Gebhardt, C. (1996):** A PCR-based approach for isolating pathogen-resistance genes from potato with potential for wide application in plants. *Nat. Genet.* 14: 421–429.
- Manganaris, A.G., Alston, F.H., Weeden, N.F., Aldwinckle, H.S., Gustafson, H.L. & Brown, S.K. (1994):** Isozyme locus PGM-1 is tightly linked to a gene (Vf) for scab resistance in apple. *J. Am. Soc. Hort. Ci.* 119: 1286–1288.
- Martin, G.B., Brommonschenkel, S.H., Chunwongse, J., Frary, A., Ganai, M.W., Spivey, R., Wu, T., Earle, E.D. & Tanksley, S.D. (1993):** Map-based cloning of a protein kinase gene conferring disease resistance in tomato. *Science.* 262: 1432–1436.
- Martínez-Gómez, P. & Dicenta, F. (2000):** Evaluation of resistance of apricot cultivars to a Spanish isolate of plum pox potyvirus (PPV). *Plant Breed.* 119: 179–181.
- McHale, L., Tan, X., Koehl, P. & Michelmore, R.W. (2006):** Plant NBS-LRR proteins: adaptable guards. *Genome Biol.* 7: 212. p.
- Meyers, B.C., Kozik, A., Griego, A., Kuang, H. & Michelmore, R.W. (2003):** Genome-wide analysis of NBS-LRR-encoding genes in Arabidopsis. *Plant Cell.* 15: 809–834.
- Michelmore, R.W., Paran, I. & Kesseli, R.V. (1991):** Identification of markers linked to disease resistance genes by bulked segregant analysis: a rapid method to detect markers in specific genomic regions by using segregating populations. *Proc. Natl. Acad. Sci. USA.* 88: 9828–9832.
- Michelmore, R.W. & Meyers, B.C. (1998):** Clusters of resistance genes in plants evolve by divergent selection and a birth-and-death process. *Genome Res.* 8: 1113–1130.
- Moustafa, T.A., Badenes, M.L., Martínez-Calvo, J. & Liácer, G. (2001):** Determination of resistance to sharka (plum pox) virus in apricot. *Scientia Hort.* 91: 59–70.
- Nurnberger, T., Brunner, F., Kemmerling, B. & Piater, L. (2004):** Innate immunity in plants and animals: striking similarities and obvious differences. *Immunol. Rev.* 198: 249–266.
- Ravelonandro, M., Scorza, R., Callahan, A., Levy, L., Jacquet, C., Monsion, M. & Damsteegt, V. (2000):** The use of transgenic fruit trees as a resistance strategy for virus epidemics: the plum pox (sharka) model. *Virus Research.* 71: 63–69.
- Reisch, B.J. & Pratt, C. (1996):** Grapes. In: Janick J, Moore JN (eds) *Fruit Breeding. Vol II. Vine and small fruit.* Wiley, New York USA, 297–369.
- Sun, X., Cao, Y., Yang, Z., Xu, C., Li, X., Wang, S. & Zhang, Q. (2004):** Xa26, a gene conferring resistance to *Xanthomonas oryzae* pv. *oryzae* in rice, encodes an LRR receptor kinase-like protein. *Plant Journal.* 37: 517–527.

- Takeda, K. & Akira, S. (2004):** Microbial recognition by Toll-like receptors. *Journal of Dermatological Science*. 34: 73–82.
- Takken, F.L. Albrecht, M. & Tameling, W.I. (2006):** Resistance proteins: molecular switches of plant defence. *Curr. Opin. Plant Biol.* 9: 383–390.
- Tor, M., Brown, D., Cooper, A., Woods-Tor, A., Sjolander, K., Jones, J.D. & Holub, E.B. (2004):** Arabidopsis downy mildew resistance gene RPP27 encodes a receptor-like protein similar to CLAVATA2 and tomato Cf-9. *Plant Physiology*. 135: 1100–1112.
- Tuskan, G.A., Difazio, S., Jansson, S., Bohlmann, J., Grigoriev, I. & et al. (2006):** The genome of black cottonwood, *Populus trichocarpa* (torr. & gray). *Science*. 313: 1596–1604.
- Van der Linden, C.G., Wouters, D.C.A.E., Mihalka, V., Kochieva, E.Z., Smulders, M.J.M. & Vosman, B. (2004):** Efficient targeting of plant disease resistance loci using NBS profiling. *Theor. Appl. Genet.* 109: 384–393.
- Vilanova, S., Romero, C., Abbott, A.G., Llácer, G. & Badenes M.L. (2003):** An apricot (*Prunus armeniaca* L.) F2 progeny linkage map based on SSR and AFLP markers, mapping plum pox virus resistance and self-incompatibility traits. *Theor. Appl. Genet.* 107: 239–247.
- Zhou, T., Wang, Y., Chen, J.Q., Araki, H., Jing, Z., Jiang, K., Shen, J. & Tian, D. (2004):** Genome-wide identification of NBS genes in rice reveals significant expansion of divergent non-TIR NBS genes. *Mol Genet Genomics*. 271: 402–415.
- Xiao, S., Ellwoodm S., Calis, O., Patrick, E., Li, T., Coleman, M. & Turner, J.G. (2001):** Broad-spectrum mildew resistance in *Arabidopsis thaliana* mediated by RPW8. *Science*. 291: 118–120.
- Xiao, S. (2006):** Current Perspectives on Molecular Mechanisms of Plant Disease Resistance. p. 317–333. (In A. Jaime and T. da Silva (eds.), *Floriculture, Ornamental and Plant Biotechnology*), Vol. 3, Global Science Books, UK
- Yang, S., Feng, Z., Zhang, X., Jiang, K., Jin, X., Hang, Y., Chen, J.Q. & Tian, D. (2006):** Genome-wide investigation on the genetic variations of rice disease resistance genes. *Plant. Mol. Biol.* 62: 181–193.
- Yang, S., Zhang, X., Yue, J., Tian, D. & Chen, J. (2008):** Recent duplications dominate NBS-encoding gene expansion in two woody species. *Mol. Genet. Genomics*. (2008) 280: 187–198.
- Young, N.D. (2000):** The genetic architecture of resistance. *Current Opinion in Plant Biology*. 3: 285–290.
- Deng, Z. & Gmitter, F. (2003):** Cloning and characterization of receptor kinase class disease resistance gene candidates in Citrus. *Theor. Appl. Genet.* (2003) 108: 53–61.